

Engine	DEUTZ WEICHA
Rated Power	92 kW
Operating Weight	10,300 Kg
Pay Load	3000 Kg
Bucket Sizes	1.7 m ³
Standard Breakout Force	100 kN
Standard Dump Clearance	2910 mm
Cabin	Air Conditioned

CLG 836 BSIII

WHEEL LOADER



TOUGH WORLD. TOUGH EQUIPMENT.

CLG 836 BSIII SPECIFICATIONS >>>

ENGINE	
Tier	BS III
Make	DEUTZ WEICHAH
Model	WP6G125E310
Rated Power	92 kW @ 2,200 rpm
Peak Torque	515 N.m @ 1,500 rpm
Displacement	6.7 L
Number of Cylinders	6
Aspiration	Turbocharged

TRANSMISSION	
Transmission Type	Planetary Hydraulic Shift
Transmission Configuration	Planetary
Torque Converter	Four-member double turbine
Maximum Travel Speed, fwd	35 km/h
Maximum Travel Speed, rev	14.5 km/h
Number of Speeds, fwd	2
Number of Speeds, rev	1

AXLES	
Differential Front Type	Fixed
Differential Rear Type	Oscillating
Axle Oscillation	11°

STEERING	
Steering Pump Type	Gear
Steering Configuration	Articulated
Steering Relief Pressure	14.7 Mpa

BRAKES	
Service Brake Type	Caliper dry disc
Service Brake Actuation	Air over hydraulic
Parking Brake Type	Air Over Hydraulic
Parking Brake Actuation	Manual

HYDRAULIC SYSTEM	
Main Pump Type	Gear
Main Relief Pressure	17 MPa
Raise	4.8 sec
Dump Time	1.2 sec
Float Down Time	2.6 sec
Fastest Total Cycle Time	8.4 sec

LOADER PERFORMANCE WITH STANDARD BUCKET	
Tipping Load	7,200 kg
Full turn Tipping Load	6,500 kg
Bucket Breakout Force	100 kN
Maximum Dump Angle at Full Height	45°
Dump Clearance at Full Height Discharge	2,910 mm
Dump Reach at Full Height Discharge	1,072 mm
Maximum Hinge Pin Height	3,740 mm
Maximum Digging Depth, Bucket Level	42 mm
Bucket Rollback at Ground Level	43°
Bucket Rollback at Carry	50°
Bucket Rollback at Maximum Height	63°

BUCKET CAPACITY	
General Purpose	1.7 m ³

DIMENSIONS	
Length with Bucket Down	6,880 mm
Width Over Tires	2,460 mm
Wheelbase	2,870 mm
Wheel Tread	1,850 mm
Ground Clearance	322 mm
Turn Angle, Either Side	40°
Maximum Gradeability	30°
Turning Radius, Outside of Tire	5,173 mm
Turning Radius, Center of Tire	5,394 mm
Turning Radius, Bucket Carry	5,674 mm

TIRES	
Tire Size	17.5 - 25 m ³

OPERATING WEIGHTS	
Operating Weight	10,300 kg

SERVICE CAPACITIES	
Fuel Tank	150 L
Engine Oil	13 L
Cooling System	28 L
Hydraulic Oil Tank	130 L
Transmission and Torque Converter	45 L
Axles, each	20 L

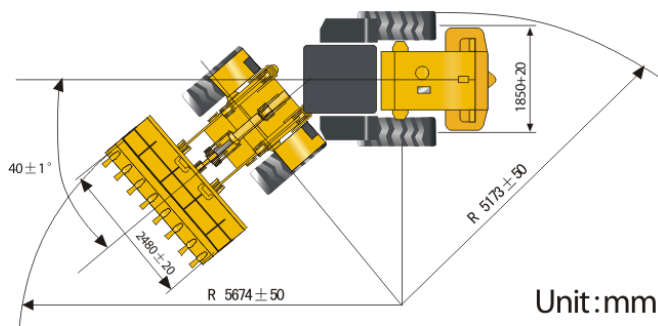
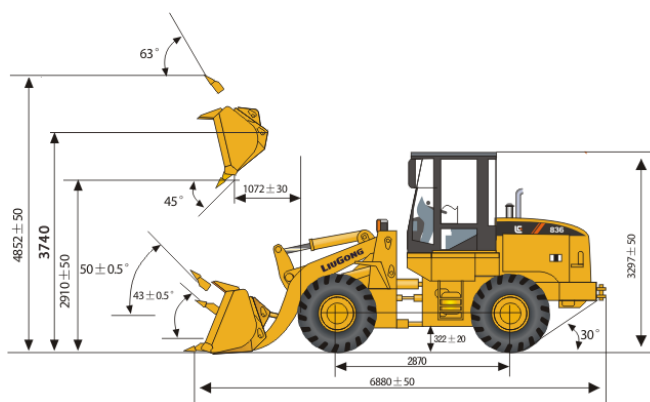

Unit:mm

Corporate office
LiuGong India Pvt. Ltd.
 82, Okhla Industrial Estate, Phase III
 New Delhi- 110020
 Tel.: 011- 47272200, Fax: 011- 47272220
 www.liugong.com
 marketing-india@liugong.com

Plant Address:
 Plot No. 163, Industrial Area,
 Sector - III, Pithampur,
 Dist. - Dhar, Madhya Pradesh - 454774
 Tel.: 07292-416700, Fax: 07292-416701

06/2014 Designed by LiuGong India

Specifications and designs are subject to change without notice. Machines shown may include optional equipment.